

Holland Snap Frame

WWW.HOLLANDSNAPFRAME.COM

De Wel 12a
3871 MV Hoevelaken, The Netherlands
Tel.: 0031 (0)33 - 25 81 179
Fax: 0031 (0)33 - 25 30 640
Email: info@hollandsnapframe
Site: www.hollandsnapframe.com

PRODUCT INFORMATION WATER FILLED PAVEMENT SIGN

Articlenumber **UWPS001000**
Max. water capacity **5 litre**
Total weight filled **8 kg**

Stable, heavy and enduring pavement sign. Suitable to set aside on parking areas, play grounds, shop entrances and busy pavement roads; especially for windy areas. Standard in metallic RAL 9006 colour. By opening the plastic stoppers, you can pour in either water or sand to make the stand heavier.

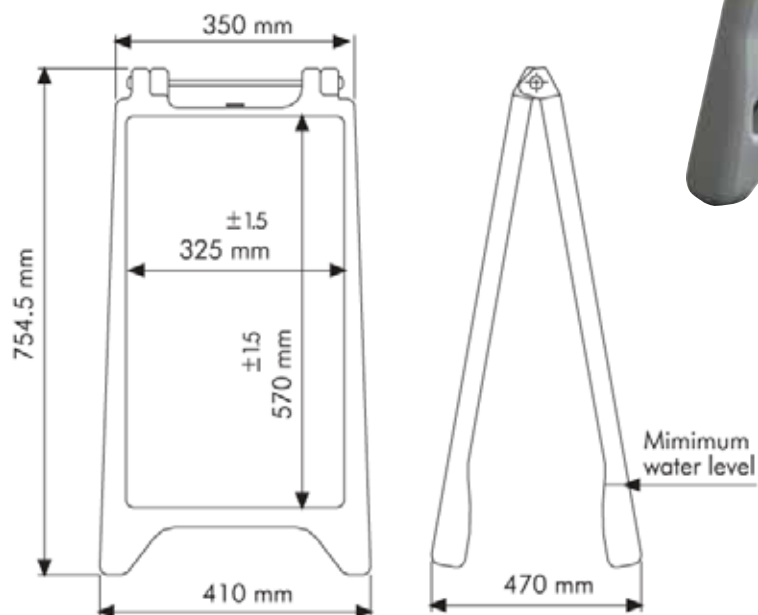

It isn't possible to derive any rights from this information. Sizes can vary. Printer's-, compositor's- and misprint errors reserved.